

CAT6A Weatherproof enclosure

9020-980



The Category 6A weatherproof enclosure is a highly durable weatherproof housing designed to allow high speed data cabling to be used in industrial or damp, internal or external locations. Whether installed in dusty factories, trade fair grounds or caravan parks the 9020-980 provides an excellent solution to keeping connections clean and dry.

Features

- Supplied with high performance Category 6A component level tool-less socket
- Angled presentation of connectors ensures adequate bend radius as required by the standard
- IP65 Rating (i.e. protected from total dust ingress and protected from low pressure water jets from any direction)
- Supplied with IP65 gland suitable for cable 4-8mm diameter
- 20mm knock-outs located top, bottom, side and back
- Corrosion Resistant
- Snap Shut Action Lid
- Padlock facility

- CE approved

Specifications

- Weight: approx. 400g
- Dimensions: approx. 152x83x101mm
- Colour: Housing and faceplate: RAL7032
- Material: Fire retardant ABS

Housing: See drawing below -

Packaging: Supplied in easily assembled kit form in individual cartons

Commodity Code: 85177090

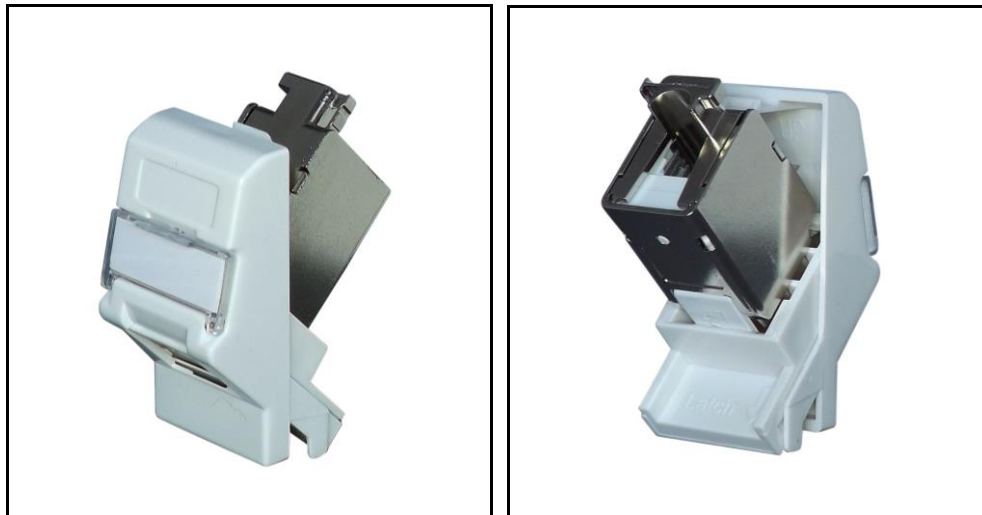

ROHS Compliant

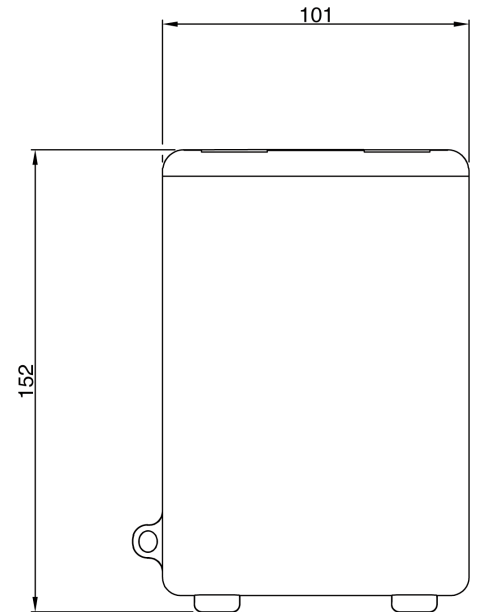
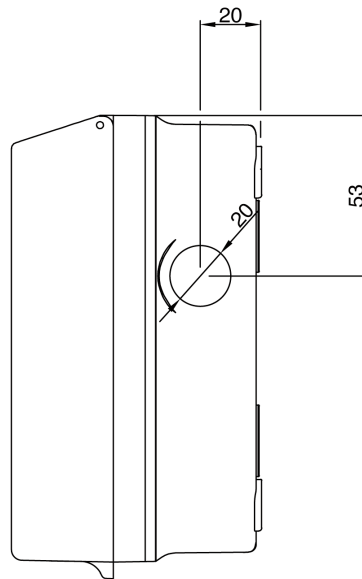
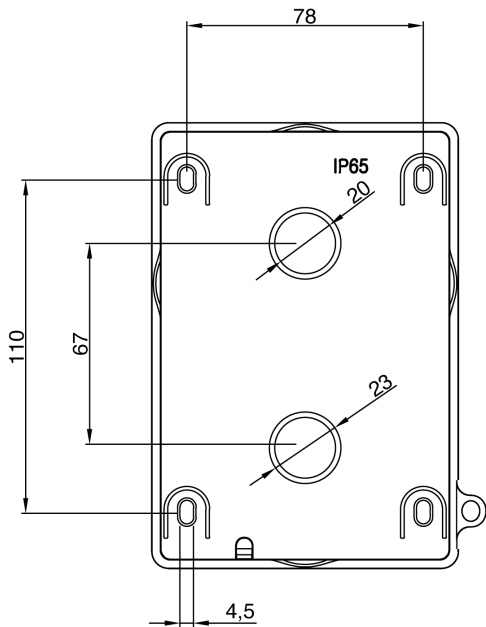
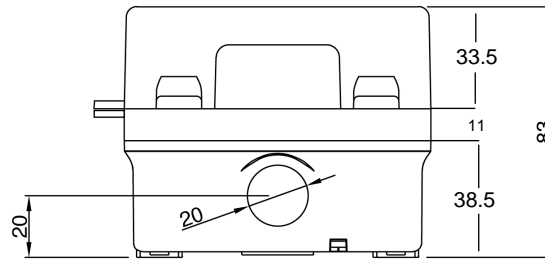
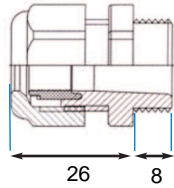

Tolerance +/- 0.5mm