

**Fibre Weatherproof enclosure**

**9020-970**



The fibre weatherproof enclosure is a highly durable weatherproof housing designed to allow LC fibre cabling to be used in industrial or damp, internal or external locations. Whether installed in dusty factories, camping sites, trade fair grounds or caravan parks the 9020-970 provides an excellent solution to keeping connections clean and dry.

**Features**

- Supplied with 2 x duplex LC connectors for termination of up to 4 cores
- Angled presentation of connectors ensures adequate cable bend radius
- Supplied with splice bridge and 3 x curly lock self-adhesive fibre management clips for ease of internal management
- Supplied with 2 x half blanks to avoid mistakes if only 2 core installation is required
- Accommodates either single mode or multimode connectors as equipped with high performance Zirconium Dioxide alignment sleeves
- IP65 Rating (i.e. protected from total dust ingress and protected from low pressure water jets from any direction)
- Supplied with IP65 gland suitable for cable 4-8mm diameter
- 20mm knock-outs located top, bottom, side and back

- Corrosion Resistant
- Snap Shut Action Lid
- Padlock facility
- CE approved

**Specifications**

- Weight: approx. 385g
- Dimensions: approx. 152x83x101mm
- Colour: Housing and faceplate: RAL7032  
Fibermod and blank: White
- Material: Fire retardant ABS
- FIBREMOD: **OL45wh** – see specification

Housing – See drawing below:

**Packaging:** Supplied in easily assembled kit form in individual cartons

**Commodity Code:** 85177090



'Curly Lock'



'Splice Bridge'

ROHS Compliant

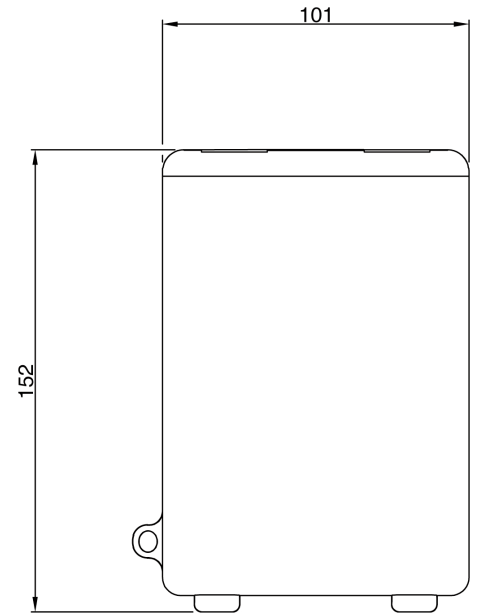
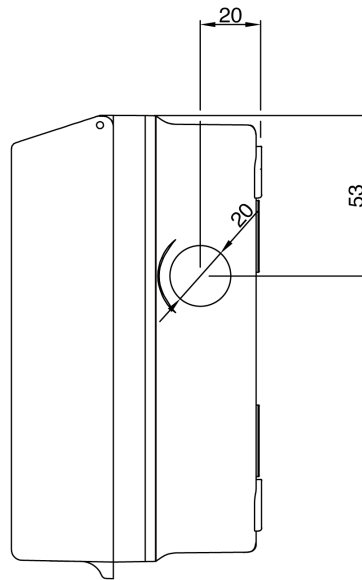
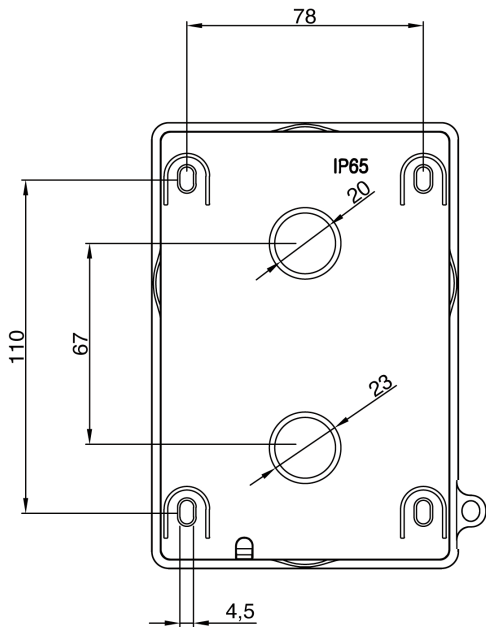
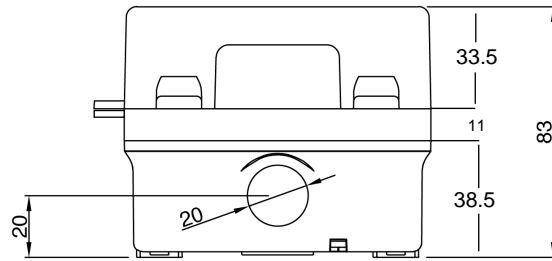
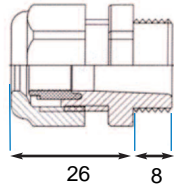

Tolerance +/- 0.5mm