

Fibre Optic Sliding Patch Panel System

FastFibre panels are designed with an emphasis on ease-of-use and access. They allow for up to 96 connections per 1U. The panels are available empty, preloaded or configured with blanks and cable management to suit your requirements. Their shallow depth allows for installation in all standard 19" racks and wall-mount enclosures.

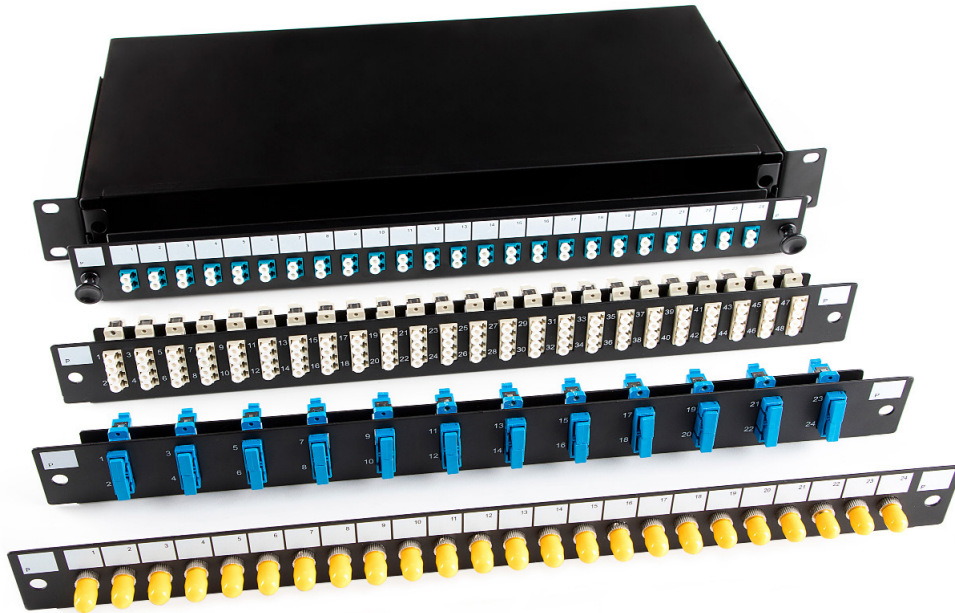

FEATURES & BENEFITS

- 1U 19" panels (black standard, other colours to order)
- LC, SC, ST, FC or E2000 adaptors
- Sliding tray for easy access complete with quick release fastenings and 45° working position
- Rigid, lightweight construction
- Recessable adaptors and mounting ears to maximise space for patching
- Large port identification write-on fields
- Interchangeable front plate for maximum flexibility
- Raised slots in the panel base allow for customised fibre-management configurations and additional securing for incoming cables
- Knock out entry for large diameter cables

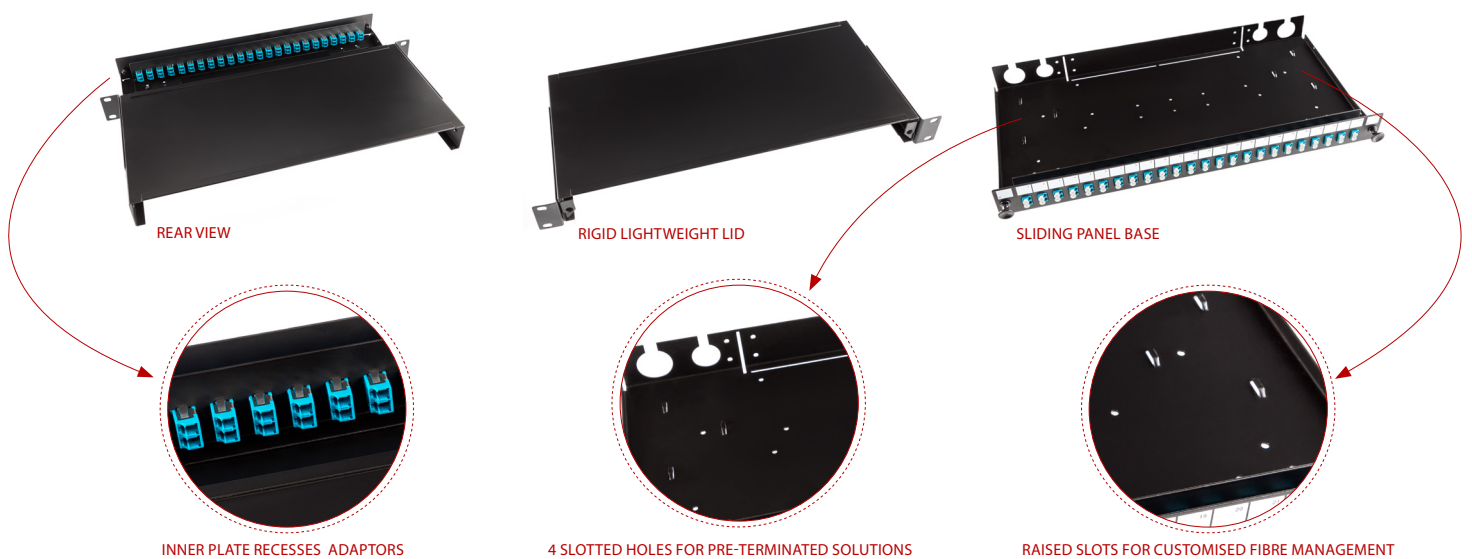

REAR VIEW

RIGID LIGHTWEIGHT LID

SLIDING PANEL BASE

INNER PLATE RECESSES ADAPTORS

4 SLOTTED HOLES FOR PRE-TERMINATED SOLUTIONS

RAISED SLOTS FOR CUSTOMISED FIBRE MANAGEMENT

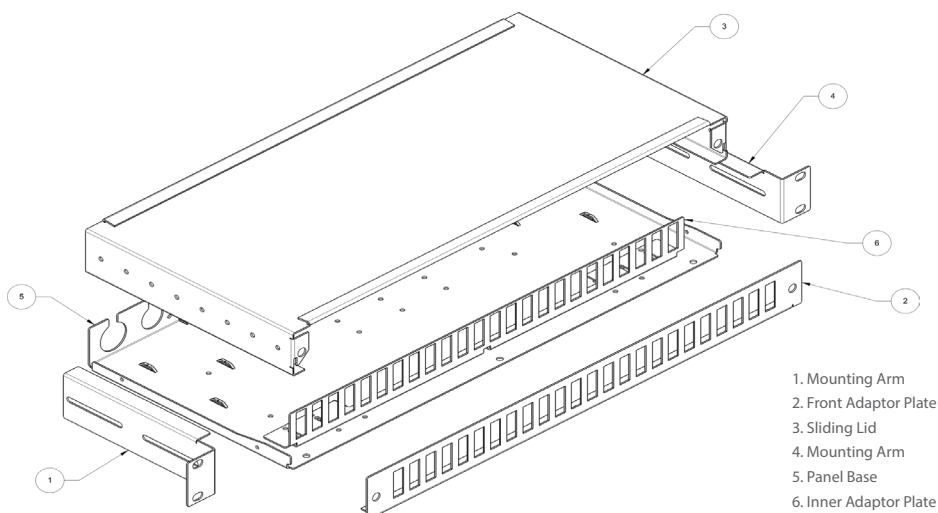
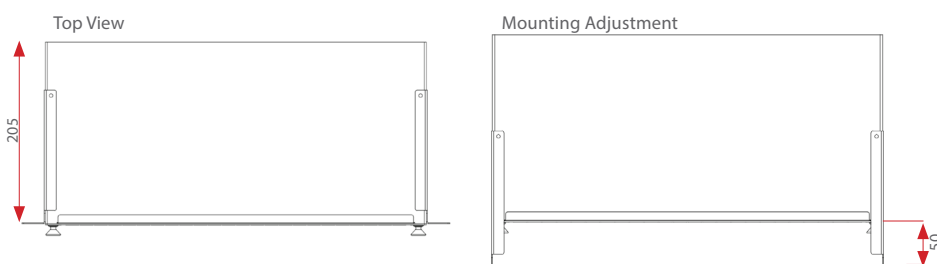
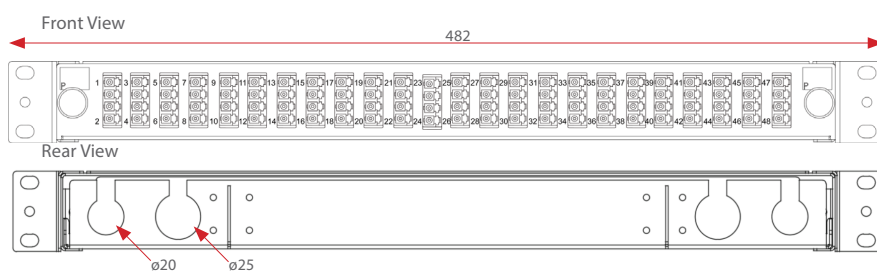

Optical Adaptor Type



Height x Width x Depth	1U 44.4mm x 482mm x 205mm
Net Weight	2.4kg
Packaged Weight	3kg
Packaged Dimensions	(H) 55m x (W) 530mm x (D) 260mm
IP Rating	20
Adaptor Type Suitability	SC Simplex (24 fibre), SC Duplex (48 Fibre), ST/FC (16/24 Fibre), E2000 (24 Fibre), LC Duplex (48 Fibre), LC Quad (96 Fibre)
Mounting Adjustment Range	50mm
Cable Entry 20mm	2
Cable Entry 25mm	2
Material Thickness	1.2mm
Material Coating	Electrostatic Powder Coating
Colour	Black RAL 9004
Operating Temperature	-40°C to +60°C
Compliant to	This product conforms to the material requirements of RoHS2, REACH/SvHC
Designed in accordance with	TIA/EIA 568A.C, ISO/IEC 11801, EN50173, IEC 60304, IEC 61754, EN297-1