

MATERIAL LIST:

NO.	PARTS NAME	SPECIFICATION DESCRIPTION
①	CABLE	HDMI1.4 32#1P+A)*5+32#4C+A+D OD:5.0 1/0.20CCS SUPPORTS 1920*1080P/60HZ
②	HDMI CONNECTOR	HDMI A TYPE 19P MALE INSULATOR BLACK PIN GOLD PLATED GOLD PLATIED SHELL
③	MOLDING PVC	MOLDING PVC 063 45P COLOR:BLACK

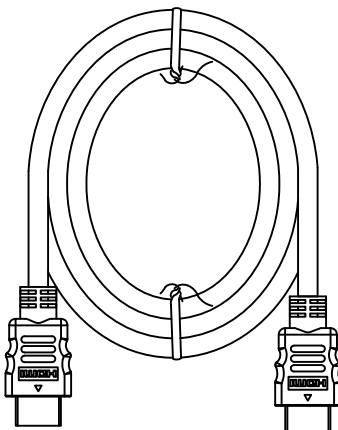

PIN OUT

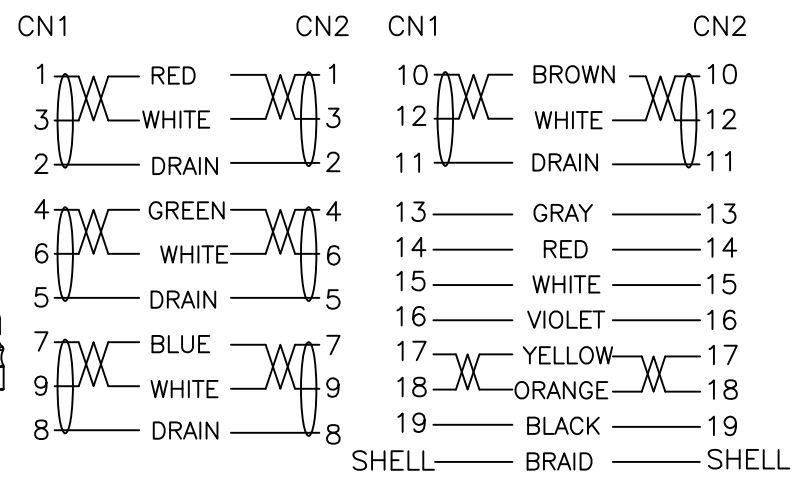

Marking: HIGH SPEED HDMI® CABLE AWM E200765 STYLE 20276 80°C 30V FT2

ELECTRONIC TEST:

- A.OPEN/SHORT/INTERMITTENCE: 100%.
- B.HI-POT: 300V DC/sec
- C.INSULATION RESISTANCE: 10M ohm (MIN)
- D.CONDUCTIVE RESISTANCE: 5ohm (MAX)

REMARK	NO	CHA.NO	SIGNATURE	DATE
DRAWN BY		Renzhi		
CHECKED BY				
AUDITED BY			APPROVED BY	
CRAFT			DATE	2011,01,07

SIGN	REV.	SCALE
	A	
PAGE OF		

1098-9X